

Sunbeam

Slow Cooker

Instruction Booklet

This book covers the use and care of the following Sunbeam slow cookers:

HP5500 Slow Cooker - 5.5 litre slow cooker with crock insert

HP4500 Slow Cooker - 4.5 litre slow cooker with crock insert

Please read these instructions carefully
and retain for future reference.



Contents

Sunbeam's Safety Precautions	1
Features of your Slow Cooker 5.5L - HP5500	2
Features of your Slow Cooker 4.5L - HP4500	4
An introduction to Slow Cooking	6
Using your Slow Cooker	6
Tips for Slow Cooking	7
Care and Cleaning	8
Recipes	
Soups	9
Main Meals	11
Desserts	20

Important instructions – retain for future use.

تأكد من تفهم احتياطات السلامة المذكورة اعلاه

請務必理解上述的安全預防措施。

Assurez-vous que les précautions ci-dessus relatives à la sécurité sont bien comprises

Versichern Sie sich daß die obenstehenden Sicherheitsmaßnahmen Verstanden werden

Βεβαιώνετε πως οι παραπάνω προφυλάξεις ασφαλείας γίνονται κατανοητές

Pastikan bahwa tindakan-tindakan keselamatan seperti di atas dimengerti anda

Accertatevi che le suddette norme di sicurezza siano comprese a dovere

上記の注意事項をよくお読みになり、安全を御確認ください

Уверете се дека погоре споменатите мерки на претпазливост се добро разбрани

Asegúrese de que las precauciones de seguridad precedentes sean bien comprendidas

کاری بکنید کہ احتیاطهای بالا حتماً درک بشوند

ต้องแน่ใจว่า ข้อควรระวังเรื่องความปลอดภัยข้างต้น เป็นที่เข้าใจกันดี

Yukarda belirtilen güvenlik önlemlerinin anlaşıldığundan emin olunuz

Xin kiểm chắc rằng những biện pháp làm an toàn kể trên được hiểu rõ

Sunbeam's Safety Precautions

SAFETY PRECAUTIONS FOR YOUR SUNBEAM SLOW COOKER.

- Do not operate the slow cooker on an inclined surface.
- Do not move or cover the slow cooker while in operation.
- Do not immerse the base of the slow cooker in water or any other liquid.
- Use your slow cooker well away from walls and curtains.
- Do not use your slow cooker in confined spaces.
- Do not touch any metal surface of the slow cooker whilst in use as it will be hot.

Sunbeam are very safety conscious when designing and manufacturing consumer products, but it is essential that the product user also exercise care when using an electrical appliance. Listed below are precautions which are essential for the safe use of an electrical appliance:

- Read carefully and save all the instructions provided with an appliance.
- Always turn the power off at the power outlet before you insert or remove a plug. Remove by grasping the plug - do not pull on the cord.
- Turn the power off and remove the plug when the appliance is not in use and before cleaning.
- Do not use your appliance with an extension cord unless this cord has been checked and tested by a qualified technician or service person.
- Always use your appliance from a power outlet of the voltage (A.C. only) marked on the appliance.
- Close supervision is necessary when your appliance is being used near children or infirm persons.
- Never leave an appliance unattended while in use.
- Young children should be supervised to ensure that they do not play with the appliance.
- Do not use an appliance for any purpose other than its intended use.
- Do not place an appliance on or near a hot gas flame, electric element or on a heated oven. Do not place on top of any other appliance.
- Do not let the power cord of an appliance hang over the edge of a table or bench top or touch any hot surface.
- For safety reasons and to avoid maintenance by unskilled persons, some appliances are 'sealed' using tamperproof screws. Such appliances should always be returned to the nearest Sunbeam Appointed Service Centre for adjustment or repair if required.
- Do not operate any electrical appliance with a damaged cord or after the appliance has been dropped or damaged in any manner. If damage is suspected, return the appliance to the nearest Sunbeam Appointed Service Centre for examination, repair or adjustment.
- For additional protection, Sunbeam recommend the use of a residual current device (RCD) with a tripping current not exceeding 30mA in the electrical circuit supplying power to your appliances.
- Do not immerse the appliance in water or any other liquid unless recommended.

If you have any concerns regarding the performance and use of your appliance, please visit www.sunbeam.com.au or contact the Sunbeam Consumer Service Line. Ensure the above safety precautions are understood.

Features of your Slow Cooker 5.5L - HP5500

Removable Crock Insert

The durable crock insert is removable to allow for convenient serving at the table, storing of leftovers and easy cleaning. The crock insert is also dishwasher safe for added convenience.

Quality Glass Lid

Fits neatly onto the crock insert to retain heat and moisture for best results. The transparent glass allows you to view the food during cooking without lifting the lid, preventing the heat from escaping.

Temperature Control Dial

Allows you to select the desired temperature for each recipe. LOW for simmering and slow cooking, HIGH for faster cooking, and the AUTO setting which regulates cooking temperatures from high heat to a lower heat automatically.

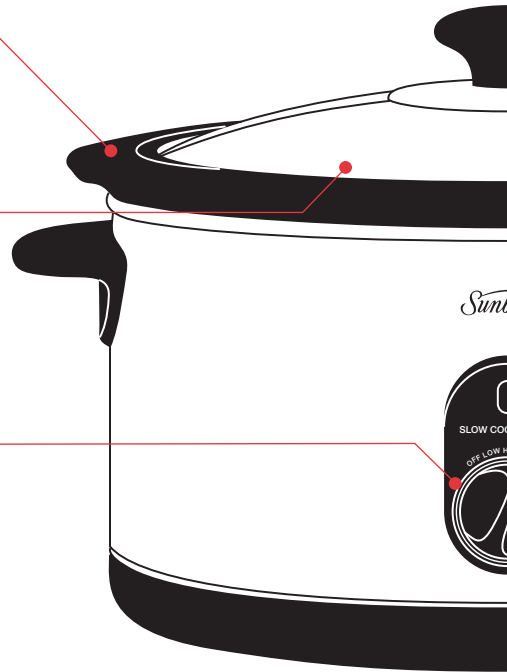

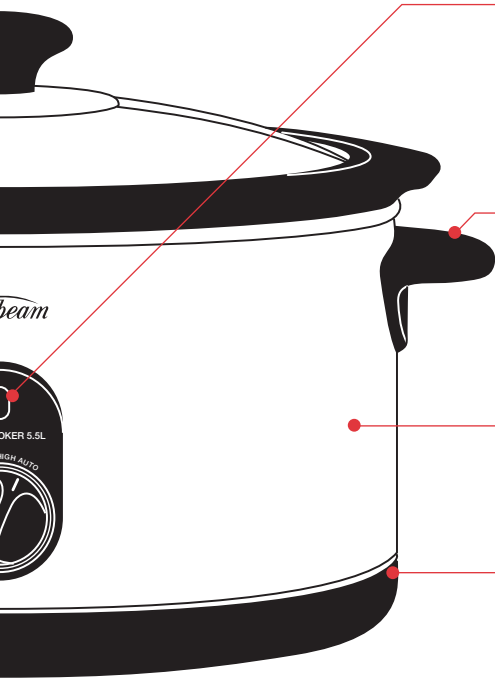

Power ON Light

Indicates that the slow cooker is turned on and heating.

Cool Touch Handles and Lid Knob

Allows you to lift and carry the slow cooker to the table for serving when hot.

Large 5.5 Litre Capacity

For cooking family-sized meals.

Wrap-Around Element

The element surrounds the crock insert to ensure even cooking. It prevents food from sticking to the bottom of the crock insert and eliminates the need to stir your food.

Features of your Slow Cooker 4.5L - HP4500

Removable Crock Insert

The durable crock insert is removable to allow for convenient serving at the table, storing of leftovers and easy cleaning. The crock insert is also dishwasher safe for added convenience.

Quality Glass Lid

Fits neatly onto the crock insert to retain heat and moisture for best results. The transparent glass allows you to view the food during cooking without lifting the lid, preventing the heat from escaping.

Temperature Control Dial

Allows you to select the desired temperature for each recipe. LOW for simmering and slow cooking, HIGH for faster cooking, and the AUTO setting which regulates cooking temperatures from high heat to a lower heat automatically.

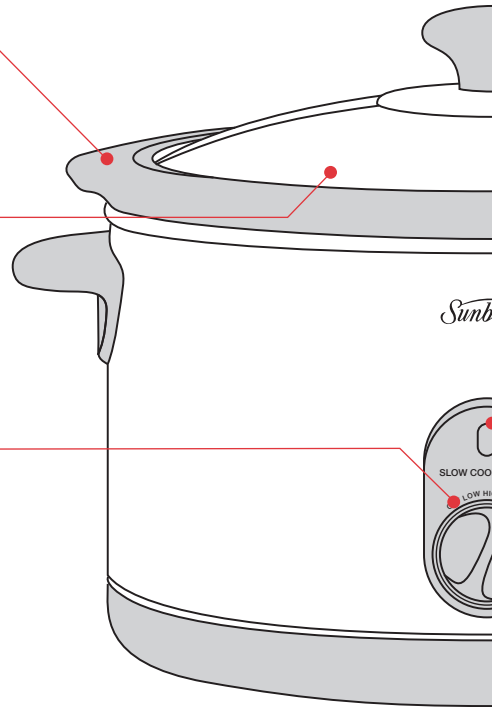

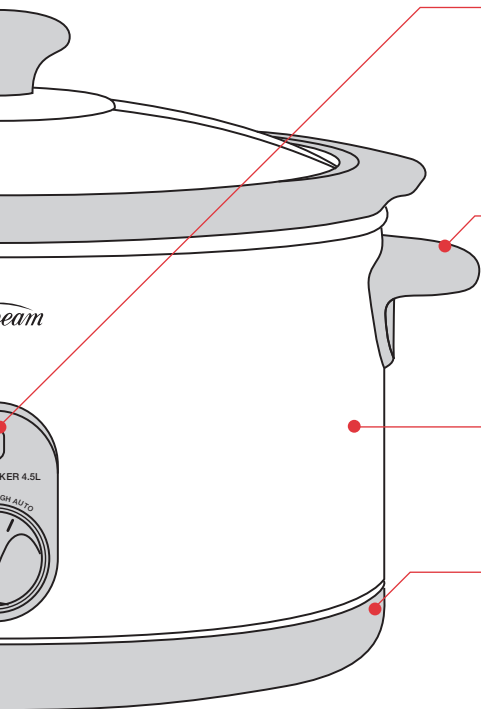

Power ON Light

Indicates that the slow cooker is turned on and heating.

Cool Touch Handles and Lid Knob

Allows you to lift and carry the slow cooker to the table for serving when hot.

4.5 Litre Capacity

Suitable for a smaller sized family.

Wrap-Around Element

The element surrounds the crock insert to ensure even cooking. It prevents food from sticking to the bottom of the crock insert and eliminates the need to stir your food.

An Introduction to Slow Cooking

Slow cooking is one of the best ways of preparing foods to ensure that the flavour and tenderness is retained. Your new slow cooker is easy to use and is extremely versatile. You can cook soups, stews, casseroles, roasts, bake desserts and even steam puddings. Slow cooking is also economical, as your new slow cooker uses very little power. Once the slow cooker reaches the selected temperature, the food cooks using the heat retained in the crock insert.

Your slow cooker is ideal for cooking tougher cuts of meat as the slow, moist heat tenderises it and enhances the flavours. Your slow cooker is also very safe for keeping foods heated, as it operates at temperatures high enough to prevent the growth of harmful bacteria.

Using your Slow Cooker

1. Before using your Sunbeam slow cooker for the first time, remove the crock insert and lid and wash them in warm soapy water. Dry thoroughly and replace.
2. Place the slow cooker on a flat level surface.
3. Prepare the food to be cooked and place inside the slow cooker. Replace the lid.
Note: Do not place very cold or frozen food in the crock insert if it has been pre-heated.
Important: The crock insert should not be placed under hot water if it has been taken directly from the freezer.
4. Insert the plug into a 230-240V power outlet and turn the power ON.
5. Select the desired setting on the temperature control dial: LOW, HIGH, or AUTO. The power on light will illuminate to indicate that the appliance is switched on.
Note: During the AUTO setting, heating temperatures will fluctuate from high heat in the initial cooking stages, settling down to a lower heat setting, automatically, for the cooking duration.

Tips for Slow Cooking

- All of the recipes contained in this book have recommended temperature settings. Most recipes can be cooked on the LOW setting, however when using the HIGH setting cooking times can often be halved.
- Cut meat and vegetables into standard size pieces for even cooking.
- When cooking with vegetables, place them in the crock insert first, and then place the meat on top.
- Always ensure that food or liquid comes to at least half way up the wall of the crock insert, as the element is located on the sides of the slow cooker.
- When roasting whole pieces of lamb, beef or chicken, it is not necessary to add liquid. Pot roasts and corned meats should be barely covered with liquid.
- Do not use oven bags when roasting lamb, beef or chicken.
- When preparing meat for casseroles, lightly coat the pieces in flour and brown before adding to the slow cooker. This helps to seal in the juices and flavours, and keeps the meat tender.
- Frozen casseroles can be placed in the cold slow cooker and heated for 5-8 hours, depending on the quantity. Do not place frozen food into a heated slow cooker.
- If a recipe results in too much liquid, turn the slow cooker to the HIGH setting, remove the lid and cook until sufficient liquid has evaporated.
- To thicken a casserole, set the slow cooker to the HIGH setting and stir through a thickening agent such as cornflour combined with a little water. Allow to simmer until thickened, stirring occasionally.
- Stirring is rarely necessary, as the element wraps around the sides of the slow cooker, preventing the food from sticking to the base.
- Leave the lid on the slow cooker during cooking to maintain heat and moisture.

Care and Cleaning

Wash the crock insert and lid in hot soapy water. To remove food that is cooked onto the bottom, soak the crock insert in warm water before cleaning and scrub lightly with a plastic or nylon brush. Rinse well and dry. The crock insert is also dishwasher safe for added convenience.

Note: Do not place the hot crock insert under cold water.

Wipe the exterior of the slow cooker with a damp cloth and polish dry. **DO NOT** use harsh abrasives, scourers or chemicals to clean any part of your slow cooker as these will damage the surfaces.

CAUTION: Do not immerse the base of the slow cooker in water or any other liquid.

Recipes

SOUPS

Mushroom & Barley Soup

Serves 4-6

- 1 tablespoon olive oil
- 2 onions, chopped
- 2 cloves garlic, crushed
- ¾ cup pearl barley
- 4 carrots, diced
- 3 stalks celery, diced
- 500g mushrooms, sliced
- ¼ cup soy sauce
- 6 cups chicken stock
- Freshly ground black pepper

1. Heat olive oil in a saucepan, cook onion and garlic for 2-3 minutes or until softened. Transfer to slow cooker.
2. Add remaining ingredients, except pepper. Cover and cook on HIGH 3-4 hours or LOW 6-8 hours.
3. Serve hot with freshly ground black pepper.

Pea and Ham Soup

Serves 6-8

- 1 tablespoon olive oil
- 2 onions, chopped
- 3 rashers bacon, diced
- 2 cups split peas
- 1- 1.5kg ham bone
- 2 litres water
- 2 large carrots, diced
- 2 sticks celery, sliced
- 2 bay leaves
- 2 tablespoons chopped fresh thyme
- Freshly ground black pepper

1. Heat oil in a large frypan, cook onion and bacon for 2-3 minutes or until onion is soft and bacon is slightly browned. Transfer to slower cooker.

2. Add remaining ingredients, reserving 1 tablespoon of fresh thyme. Cook on HIGH 3-4 hours or LOW 6-8 hours.
3. Remove ham bone from slow cooker. Pull off meat from the bone, removing excess fat and skin. Dice and return to the soup.
4. Stir through remaining thyme and season with freshly ground black pepper.

Tip: Ask your butcher to cut the ham bone into pieces.

Potato and Leek Soup

Serves 4

- 1 tablespoon olive oil
- 2 rashers bacon, chopped
- 3 medium leeks, sliced thinly
- 1 kg potatoes, peeled and diced
- 4 cups chicken stock
- Freshly ground black pepper
- ½ cup grated parmesan

1. Heat oil in a large saucepan; add bacon and cook, stirring occasionally, until crisp. Remove from pan.
2. Add leeks to the same pan and cook, stirring for about 5 minutes or until leeks are tender. Transfer to slow cooker.
3. Add remaining ingredients, except pepper and parmesan in slow cook. Cook on HIGH for 3-4 hours or LOW 6-8 hours. Cool before blending.
4. Blend or process cooled soup until smooth. Add bacon and reheat in slow cooker for about 1 on high, or until hot.
5. Season to taste with freshly ground pepper.
6. Serve soup topped with parmesan cheese.

Tip: This recipe may be doubled if desired.

Recipes continued

French Onion Soup

Serves 4-6

- 20g butter
 - 1 tablespoon olive oil
 - 4 large onions, finely sliced
 - 1 large clove garlic, crushed
 - 1 tablespoon plain flour
 - 4 cups beef stock
 - 2 tablespoons brandy
 - 1 Baguette, thickly sliced
 - 1 cup grated Gruyere cheese or ½ cup parmesan
1. Heat butter and oil in a large saucepan over medium heat. Add onion and garlic and cook 2-3 minutes or until onion becomes transparent and soft. Make sure it does not colour.
 2. Add flour and coat onion mixture. Gradually add brandy and 1 cup of stock. Cook for 3-5 minutes or until alcohol has evaporated. Transfer to slow cooker and add remaining stock.
 3. Cover and cook on HIGH 3-4 hours or LOW 6-8 hours.
 4. Place bread on a baking tray in one layer, brush or spray with oil. Bake 5-10 minutes or until bread is crisp and lightly coloured. Top bread with cheese and cook a further 5 minutes or until cheese has melted.
 5. To serve, place a slice of bread in a soup bowl, ladle in soup and top with extra cheese.

Creamy Pumpkin Soup

Serves 4

- 2 tablespoon olive oil
 - 1 onion, chopped
 - 1.5kg pumpkin, diced
 - 4 cups chicken stock
 - Sea salt & freshly ground black pepper
 - ⅓ cup cream or sour cream to serve (optional)
1. Heat oil in a large frypan over medium heat, add onion and cook 2-3 minutes, or until onion is soft.
 2. Add diced pumpkin, cook, stirring, until pumpkin begins to soften and colour slightly. Transfer to slow cooker.
 3. Add chicken stock and cook on HIGH 1-2 hours or LOW 3-4 hours. Cool before pureeing.
 4. Blend or process cooled soup until smooth. Reheat in slow cooker for about 1 hour on HIGH or until hot.
 5. Serve with cream and extra ground black pepper.

Recipes continued

MAIN MEALS

Roasting Beef

Place meat into the slow cooker and cook.

Approximate cooking times for well done:

LOW 2-2½ hours per 500g

HIGH 1-1½ hours per 500g

Roasting Lamb

Cut away excess fat. Place meat into the slow cooker. Cover and cook as desired.

Approximate cooking times for well done:

LOW 2 - 2½ hours per 500g

HIGH 1 - 1½ hours per 500g

No need to turn meat during cooking.

Roasting Chicken

Wash chicken and pat dry. Stuff if desired and truss. Place chicken into the slow cooker and cover.

Approximate cooking times:

LOW 1½ - 2½ hours per 500g

HIGH 1 - 1½ hours per 500g

Dot with butter and sprinkle with paprika to add extra colour.

Corned Beef

Serves 6

1.5kg corned silverside

1 onion, finely chopped

10 peppercorns

2 bay leaves

2 tablespoons brown sugar

1. Place silverside into the slow cooker and barely cover with water. Add remaining ingredients.
2. Cover and cook on LOW for 8-10 hours or on HIGH for 4-6 hours.
3. Serve with boiled potatoes and vegetables.

Roast Chicken

Serves 4

1 size 12 chicken

butter, melted

parsley, finely chopped

paprika

Stuffing:

2 cups fresh breadcrumbs

Rind from 1 lemon

1 rasher bacon, finely chopped

1 egg, lightly beaten

1 teaspoon parsley

1. Combine all ingredients for stuffing. Place into cavity of chicken and truss.
2. Pat chicken dry and place into the slow cooker. Brush chicken with butter and sprinkle with parsley and paprika.
3. Cover and cook on LOW for 6-8 hours or HIGH for 3-4 hours.

Recipes continued

Moroccan Chicken

Serves 4-6

2kg chicken pieces, skin and fat removed
1/3 cup plain flour
Sea salt and freshly ground black pepper
3 tablespoons olive oil
1 onion, sliced
2 cloves garlic, crushed
1 tablespoon ground cumin
1 tablespoon ground coriander
1 teaspoon turmeric
1/4 teaspoon ground cinnamon
1/2 cup chicken stock
415g can apricot halves in natural juice
Cous cous, to serve

1. Wash chicken and pat dry. Lightly coat the chicken in the flour seasoned with salt and pepper; shake off excess.
2. Heat oil in a frying pan and cook chicken in batches, until browned all over. Transfer to slow cooker.
3. Using the same pan, add the onions and cook, stirring, until slightly softened. Add the garlic, cumin, coriander, turmeric and cinnamon and cook until fragrant. Add the stock and the juice from the apricots.
4. Pour the onion and spice mixture over the chicken and top with apricot halves.
5. Cover and cook on HIGH 3-4 hours or LOW 6-8 hours.
6. Season to taste, serve chicken with cous cous.

Coq au Vin

Serves 4 - 6

2kg chicken pieces, skin and fat removed
1/2 cup flour
100g butter
2 tablespoon olive oil
12 pickling onions, peeled
4 rashers bacon, chopped
1 cup dry red wine
1/4 cup brandy
1 cup chicken stock
200g button mushrooms, sliced
1 tablespoon chopped fresh thyme
1 teaspoon mixed herbs
2 bay leaves
Salt and freshly ground black pepper

1. Coat chicken pieces in flour and shake off excess. Heat butter and oil in a large frypan over medium heat and add chicken in batches and cook until brown, transfer to slow cooker.
2. In the same pan, add onions, bacon and garlic and cook for about 3-5 minutes, or until onions are lightly brown.
3. Add wine and brandy to pan and simmer gently for 5 minutes, scraping up all the pan sediment in the process.
4. Pour onion, bacon and wine mixture into slow cooker with the remaining ingredients. Cook on HIGH 3-4 hours, LOW 6-8 hours.
5. Season to taste, serve with crusty fresh bread.

Recipes continued

Chicken, Mustard and Sage Casserole

Serves 6-8

2kg thigh cutlets, fat and skin removed

1/3 cup plain flour

1/4 cup olive oil

3 large leeks, washed and sliced thickly

2 cloves garlic, crushed

1/2 cup dry white wine

1kg kumara, peeled and cut into large chunks

1 cup chicken stock

Zest of one lemon

2 tablespoons Dijon mustard

Salt and pepper

1 tablespoon chopped fresh sage

1. Dust chicken in flour, shaking off excess flour. Heat oil in a large frypan and cook chicken in batches until brown. Transfer to a plate.
2. Heat remaining oil in frypan, cook leeks and garlic together until leeks have softened. Add wine and cook for 1 minute or until the alcohol has evaporated.
3. Place kumara into the base of slow cooker and top with chicken and onion mixture. Add remaining ingredients, except sage. Cover and cook on HIGH 3-4 hours or LOW 6-8 hours.
4. Season to taste and sprinkle with sage. Serve with rice.

Chicken and Olive Casserole

Serves 4-6

2kg chicken pieces, skin and fat removed

1/2 cup plain flour

3 tablespoons olive oil

2 onions, chopped

2 cloves garlic, crushed

1 medium tomato, roughly chopped

1 cup pitted green olives

1 bunch baby carrots, top and tailed

1 tablespoon chopped fresh thyme

1 tablespoon chopped fresh oregano

1 cup chicken stock

Salt and freshly ground black pepper to taste

1. Dust chicken pieces in plain flour. Heat oil in a large frypan; add chicken in batches and cook until well browned. Remove and place in slow cooker.
2. Add onion & garlic and cook 1-2 minutes, or until onion has softened. Place in slow cooker with remaining ingredients. Cover and cook on HIGH 3-4 hours or LOW 6-8 hours.
3. Season to taste and serve hot with creamy mashed potatoes.

Recipes continued

Lemongrass and Ginger Scented Chicken

Serves 4-6

1 tablespoon olive oil
2kg chicken thigh fillets, skin and fat removed
2 medium onions, sliced
3 cloves garlic, crushed
5cm piece ginger, peeled, sliced
2 large red chillies, seeded, sliced
2 stalks lemongrass, trimmed, bruised
½ cup chicken stock
¼ cup soy sauce
2 tablespoons oyster sauce
Freshly ground black pepper
200g sugar snap peas

1. Heat oil in a large frypan until hot; seal sides of chicken in batches, then quickly remove from pan. Transfer to slow cooker.
2. Reduce heat; add onions and garlic and cook for 1-2 minutes, place in slow cooker with remaining ingredients except sugar snap peas.
3. Cover and cook on HIGH 3-4 hours or LOW 5-6 hours.
4. About 15 minutes before serving, add the sugar snap peas and gently stir through. Cover and cook until the peas are just tender.
5. Garnish with remaining chilli and serve with steamed rice.

Lamb Roast with White Beans and Parsley Sauce

Serves 4

1.4kg – 1.5kg lamb roast, easy carve
1-2 cloves garlic, cut into slivers
2 sprigs fresh rosemary, snipped into pieces
2 tablespoons olive oil
20g butter
1 large onion, sliced
1 x 400g can butter beans, rinsed and drained
¼ cup chopped fresh parsley
½ cup chicken stock
salt and pepper

1. Make small incisions all over lamb with a very sharp knife, then stuff each with a sliver of garlic and a sprig of rosemary.
2. Heat oil in a large frying pan, cook lamb until browned all over. Remove from pan and transfer to slow cooker.
3. In the same pan, add butter and cook onion 1-2 minutes or until transparent, place in slow cooker with remaining ingredients.
4. Cover and cook on HIGH 3-4 hours or LOW 6-8 hours. Season with salt and pepper.
5. Remove meat from slow cooker and rest for 10 minutes before carving. Serve slices of lamb with beans and parsley sauce.

Recipes continued

Spicy Lamb Curry

- 1 tablespoon vegetable oil
- 2.5kg lamb forequarter chops, trimmed of fat
- 14-16 fresh curry leaves
- 2 teaspoons black mustard seeds
- 1 medium onion, roughly chopped
- 2 cloves garlic, crushed
- 2 tablespoons grated fresh ginger
- 2 tablespoons curry powder
- 1 tablespoon tandoori paste
- 1 tablespoon ground cumin
- 2 teaspoons garam masala
- 3 teaspoons chilli powder
- 2 tablespoons lemon juice
- ½ cup water
- 1 cup roughly chopped fresh coriander

1. Heat oil in a large fry pan, cook lamb in batches until brown. Place in slow cooker.
2. In remaining oil, fry mustard seeds and curry leaves until seeds begin to pop. Add onion and garlic and cook until onion is soft. Add dry spices and fry 1-2 minutes until spices are fragrant.
3. Add remaining ingredients, except coriander to slow cooker and cook on HIGH 3-4 hours or LOW 6-8 hours.
4. Season to taste and sprinkle with fresh coriander. Serve with steamed basmati rice.

Lamb Tagine

- 2 tablespoons olive oil
- 8 lamb shanks, fat trimmed
- 1 large onion, sliced thinly
- 2 cloves garlic, crushed
- 1½ tablespoons Moroccan dried spice mix
- 1 tablespoon tomato paste
- 1 x 400g tin chopped peeled tomatoes
- ½ cup chicken stock
- 1 x 400g tin chickpeas, drained and rinsed
- 1 large sweet potato, peeled and chopped into 2 cm dice
- 1 cinnamon stick
- 3 cardamom pods, cracked
- Salt and pepper to taste
- 1 cup fresh coriander, roughly chopped
- Cous cous, to serve

1. Heat oil in a large frypan over medium high heat, cook lamb shanks in batches for 3-5 minutes or until evenly browned all over. Place into slow cooker.
2. Reduce heat and add onion and garlic to frypan and cook for 5 minutes or until onion has softened and coloured. Add spice mix and cook until fragrant. Stir through tomato paste.
3. Place onion mixture into slow cooker with remaining ingredients, except coriander. Cover and cook on HIGH 3-4 hours or on LOW 6-8 hours.
4. Adjust seasoning and stir through chopped coriander, serve with cous cous.

Recipes continued

Beef Curry

2kg diced chuck steak
½ cup flour
¼ cup vegetable oil
2 large onions, diced
2 cloves garlic, crushed
¼-⅓ cup curry paste
¼ cup tomato paste
4 medium potatoes, quartered
1 cup beef stock
Sea salt and freshly ground black pepper

1. Dust beef in flour, shaking off excess.
Heat oil in a large frypan and cook beef in batches until browned. Remove and place in slow cooker.
2. Heat remaining oil, cook onion and garlic for 2-3 minutes or until softened. Add curry powder and cook until fragrant. Transfer to slow cooker with remaining ingredients.
3. Cover and cook on HIGH for 3-4 hours or LOW for 6-8 hours.
4. Season to taste and serve with cooked basmati rice.

Serve 6-8

Family Beef Casserole with Semi Dried Tomatoes

Serves 6-8

2kg chuck or round steak cut into 2cm cubes
½ cup flour
2 tablespoons olive oil
2 bunches of spring onion, stalk trimmed, peeled and left whole
3 carrots, diced
4 celery stalks, sliced
⅓ cup tomato paste
½ cup red wine
1 cup semi dried tomatoes
2 tablespoons chopped fresh thyme
2 bay leaves
Salt and freshly ground black pepper

1. Dust beef in flour, shaking off excess flour.
Heat oil in a large frying pan and cook beef in batches until brown. Transfer to slow cooker.
2. To the same pan, add onion and garlic, cook stirring for 1-2 minutes or until onion is softened. Add carrots and celery and cook for a further 3 minutes.
3. Stir tomato paste into the vegetables, cook 1 minute. Add wine and allow alcohol to evaporate and liquid to reduce slightly. About 2 minutes.
4. Place vegetables and remaining ingredients in slow cooker. Cover and cook on HIGH 3-4 hours or LOW 5-6 hours.
5. Season to taste and serve hot with mashed potatoes or rice.

Recipes continued

Beef Stroganoff

Serves 6-8

- 2kg chuck or round steak, cut into thin strips
 - ¼ cup flour
 - ¼ cup olive oil
 - 3 cloves garlic, crushed
 - ½ cup tomato paste
 - 1 cup beef stock
 - 500g mushrooms, sliced
 - 300ml sour cream
 - Salt and freshly ground black pepper
6. Dust beef in flour, shaking off excess flour. Heat oil in a large frying pan and cook beef in batches until brown. Remove and place in slow cooker.
 7. Add remaining ingredients, except sour cream. Cover and cook on HIGH 3-4 hours or LOW 6-8 hours.
 8. In the last 30 minutes of cooking, stir through sour cream. Season with salt and pepper. Serve with buttered noodles.

Chilli Con Carne

Serves 4-6

- 2 tablespoons olive oil
- 2 onions, diced
- 2 cloves garlic, chopped
- 1.5kg mince beef
- 1 tablespoon ground cumin
- 3 teaspoons paprika
- 1 teaspoon cayenne pepper
- 1 x 400g can chopped tomatoes
- 1 x 400g can red kidney beans, rinsed and drained
- ½ cup beef stock
- 2 bay leaves
- Salt and freshly ground black pepper

1. In a large frypan, heat oil over medium high heat and cook onions and garlic for 2-3 minutes, stirring occasionally until soft.
2. Add mince to frypan in batches and cook until mince is brown and crumbly.
3. Stir through dried spices and cook a further 1 minute until fragrant.
4. Transfer mixture to slow cooker, add tomatoes, red kidney beans and bay leaves. Cover and cook on HIGH 3-4 hours or LOW 6-8 hours.
5. Remove bay leaves & season to taste, serve with rice or tortillas.

Sweet Pork with Apples and Prunes

Serves 6

- 2 tablespoon olive oil
 - 2kg forequarter pork chops, trimmed of fat
 - 3 medium red onions, cut into thick wedges
 - 4 medium green apples, cored and cut into quarters
 - 1 cup chicken stock
 - 250g seedless prunes
 - 2 tablespoons coarsely chopped fresh sage
 - salt and freshly ground black pepper
1. Heat 1 tablespoon of oil in a large frying pan over medium heat, cook pork for 1 minute each side or until lightly brown. Transfer to a plate.
 2. Heat remaining oil in frypan, add onions and cook 2-3 minutes or until onions have softened. Add apples and toss in pan, stirring frequently, until apple begins to colour. Place in bottom of slow cooker. Add stock, prunes and 1 tablespoon of fresh sage.
 3. Cover and cook on HIGH 3-4 hours or LOW 6-8 hours.
 4. Season to taste; serve with a sprinkle of fresh sage.

Recipes continued

Spinach and Ricotta Cannelloni Serves 4 - 6

2 x 250g packet frozen spinach, thawed
2 cloves garlic, crushed
500g fresh ricotta
Freshly ground black pepper
500g dried cannelloni
1kg bottled pasta sauce
Salt and freshly ground black pepper
Parmesan cheese to serve

1. Combine defrosted spinach, ricotta and garlic together. Season with pepper
2. Fill cannelloni tubes with ricotta filling, making sure not to overfill the tubes.
3. Spoon $\frac{1}{2}$ cup of pasta sauce into the base of the slow cooker. Arrange one row of cannelloni tubes over the sauce then pour over enough sauce to just cover the layer of cannelloni. Repeat with remaining cannelloni and sauce.
4. Cover and allow to cook on HIGH 1-1 $\frac{1}{2}$ hours or LOW 2 -2 $\frac{1}{2}$ hours.
5. Season to taste and sprinkle with parmesan.

Dhal Serves 4-6

2 tablespoons vegetable oil
2 medium onions, finely chopped
2 cloves garlic, crushed
1 tablespoon ground cumin
1 teaspoon cumin seeds
2 teaspoons black mustard seeds
 $\frac{1}{4}$ cup tomato paste
4 cups red lentils
2 cups vegetable stock
4 $\frac{1}{2}$ cups water
2 x 400g cans chopped tomatoes
3 baby eggplants, roughly chopped
salt to taste

1. In a large frying pan, heat oil over medium heat. Add onion and garlic and cook, stirring for 2-3 minutes or until onion is soft.
2. Add dried spices and cook a further 1 minute or until spices are fragrant. Stir through tomato paste and cook for 2 minutes. Place in slow cooker.
3. Rinse lentils in water, until water runs clear. Put in slower cooker with remaining ingredients, except salt and stir well to combine all ingredients.
4. Cook on HIGH 1-2 hours or on LOW for 4-5 hours.
5. Season to taste serve hot.

Recipes continued

Thai Chicken Red Curry

Serves 8

3 tablespoons vegetable oil
2kg chicken thigh cutlets, skin and fat removed
1 large onion, chopped into wedges
1 clove garlic, crushed
1 tablespoon grated fresh ginger
400g sweet potato, cut into 3cm pieces
125g fresh baby corn
250g cauliflower, cut into florets
2-3 tablespoons Thai red curry paste
2 cups chicken stock
1 red capsicum, sliced thickly
200g green beans, trimmed
1 x 270ml can coconut cream
4 kaffir lime leaves, shredded
2 tablespoons fish sauce
2 teaspoons palm sugar
Sea salt
Steamed jasmine rice to serve
Coriander to garnish

1. Heat 2 tablespoons of the oil in a frypan until hot; cook chicken in batches until browned, remove.
2. Heat remaining oil in frypan, add onions, garlic and ginger and cook until onion has softened. Add sweet potato, corn, cauliflower, red curry paste and chicken and cook until the vegetables and chicken are just coated in paste. Transfer to slow cooker.
3. Add stock to pan and cook, covered, on HIGH for 3 hours. Remove lid, stir through remaining ingredients and cook, covered, for a further 30 minutes or until beans and capsicum are tender.
4. Garnish with coriander sprigs and serve with steamed jasmine rice.

Ratatouille

Serves 4

1 large onion, chopped
2 cloves garlic, crushed
2 tablespoons tomato paste
2 eggplants, cut into 3 cm dice
2 medium zucchinis, sliced into 1 cm rings
1 red capsicum, deseeded and chopped into 3 cm pieces
1 green capsicum, deseeded and chopped into 3 cm pieces
2 x 400g cans chopped tomatoes
2 tablespoons chopped fresh thyme
Salt and freshly ground black pepper

1. Place all ingredients except salt and pepper in slow cooker. Cover and cook on HIGH 3-4 hours or LOW 6-7 hours.
2. Season to taste.

Recipes continued

DESSERTS

Chocolate Self- Saucing Pudding

Serves 4

100g unsalted butter, melted
½ cup milk
1 egg
1 cup self raising flour
2 tablespoons cocoa
½ cup caster sugar

Topping:

2 tablespoons cocoa
1 cup firmly packed brown sugar
2 cups boiling water

1. In a mixing bowl, combine butter, milk and egg.
2. In a separate large bowl, sift flour and cocoa together and mix in the sugar.
3. Gradually add the wet ingredients into the flour mixture and mix well. Spoon into 1.6 litre pudding basin, and place in the slow cooker.
4. Combine the cocoa and brown sugar together, sprinkle over the top of pudding. Carefully pour boiling water over the mixture.
5. Cover and cook on HIGH for 3.5 hours or on LOW for 5-6 hours.
6. Serve hot with ice-cream or custard.

Poached Pears in Red Wine and Star Anise

Serves 4-6

1½ cups dry red wine
¾ cup sugar
2 star anise
6 medium pears
3 thick strips lemon rind

1. Place wine, sugar and star anise into the slow cooker. Cover and cook on HIGH until sugar is dissolved.
2. Place pears into the slow cooker, turning to coat well with sugar syrup. Add lemon peel, cover and cook on HIGH 2-3 hours or LOW 4-6 hours, turning occasionally to coat.
3. To serve, remove pears from the slow cooker and place onto a serving plate. Pour syrup over pears. Serve with whipped cream if desired.

Spiced Rhubarb and Berry Compote

Serves 4-6

2 bunches of rhubarb, cut into 2cm pieces
500g frozen mixed berries
¾ cup sugar
1 cinnamon quill
3 whole cloves
1 teaspoon grated orange rind

1. Combine all ingredients in the slow cooker.
2. Cover and cook on LOW 3-4 hours.
3. Serve hot with ice-cream or with your favourite pudding.

Recipes continued

Steamed Christmas Pudding

Serves 6

500g mixed dried fruit

½ cup firmly packed brown sugar

90g butter or margarine

¼ cup water

1 tablespoon sherry or brandy

½ teaspoon bi-carbonate of soda

2 eggs, lightly beaten

1 cup self raising flour

½ teaspoon mixed spice

1. In a saucepan, combine mixed fruit, brown sugar, butter, water and sherry. Heat until butter is melted and mixture begins to boil.
2. Remove from heat, add bi-carbonate of soda and allow to cool completely.
3. Grease a 6 cup capacity pudding bowl.
4. Add eggs to the cooled mixture and mix until well combined. Fold through flour and spices.
5. Pour mixture into the prepared bowl, cover with a double layer of foil and tie firmly with string to form a good seal.
6. Place into the slow cooker. Pour in sufficient water to come two thirds of the way up the sides of the pudding bowl. Cover and cook on HIGH for 5-7 hours.
7. Re-heat pudding by cooking pudding in water on HIGH for 2-3 hours prior to serving. Serve with brandy custard.

'Sunbeam', is a registered trademark of Sunbeam Corporation.

Made in China. Due to minor changes in design or otherwise, the product may differ from the one shown in this leaflet. Backed by Sunbeam's 12 Month Replacement Guarantee and National Service Network.

© Copyright. SUNBEAM CORPORATION LIMITED 2005.

(INCORPORATED IN N.S.W.) A.C.N. 000 006 771

Sunbeam Corporation is a division of GUD Holdings Ltd.

For more information or advice on this or any other Sunbeam appliance, visit www.sunbeam.com.au or contact the Sunbeam Consumer Service Line.

Australia 1800 025 059

New Zealand 0800 786 232.

Sunbeam

Consumer Hotline

Australia

1800 025 059

New Zealand

0800 786 232

www.sunbeam.com.au

 is a registered Trademark of Sunbeam Corporation Limited. ACN 000 006 771.

© Sunbeam Corporation Limited 2005.